

WIZARD ARM W150 C

LIFTKON

Liftkon develops electronical rope balancers for manual handling technique, designed for rail systems or mounted on columns. The portfolio offers various weight categories as well as arm lengths for individual applications.



Details make Wizard unique ...
..and you can benefit from it

- Application of a measuring cell
The application of a measuring cell leads to an optimum running performance of the unit. The weight of the load will be weight out and displayed exactly.
- Swivel included as a standard
Available as standard, rotary units are installed on the operating handle and the column. This allows endless turning and movement of load and extension arm.
- Winding protection
Due to an effective winding protection entangled ropes are things of the past. For simple maintenance the rope can be uncoiled and rolled up by means of two additional buttons.
- Middle hinge as a standard
The middle hinge, integrated as a standard, interconnects the arm segments. This allows to reach really every point within the operating radius.

WIZARD ARM W150 C

LIFTKON

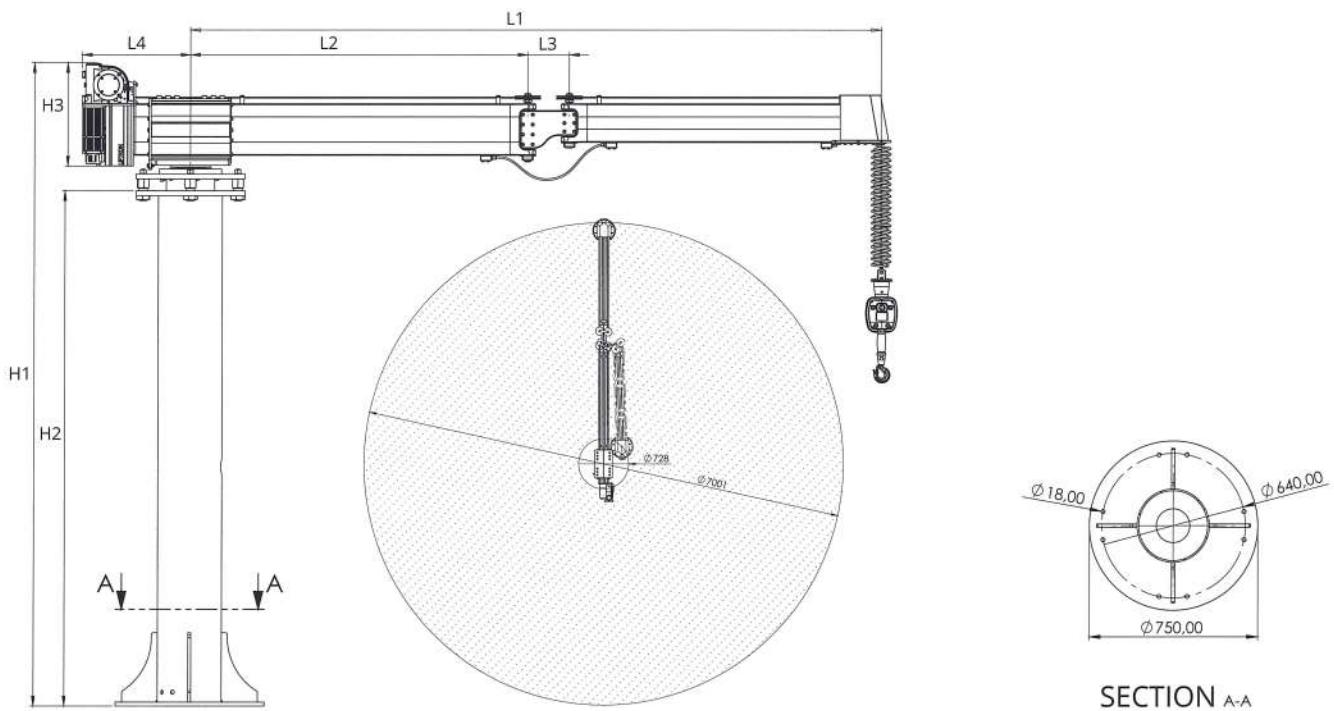

Measures	L1	L2	L3	L4	H1	H2	H3
mm	3500	1710	210	549	3240	2595	520

Technical Data

Load Capacity	max. 150 kg
Power supply	230 V / 1700 VA
Drive	Servomotor
Lifting speed	392 mm/s
Swivel arm	Light swivel arm (with middle hinge) of anodized aluminium profiles available in two lengths: 3 and 3,5 m.
Installation	Floor mounting with floor anchors. Alternative: screw connection on a mobile platform.
Control	The ups and downs are initiated by operating handle or operating unit. Upon release the handle motion is immediately stopped.

LIFTKON GmbH
 Kanalstraße 25 · 73061 Ebersbach/Fils
 Telefon +49 (0)7163 99883-00 · Telefax +49 (0)7163 99883-01
 info@liftkon.de · www.liftkon.de

Liftkon GmbH disclaims all responsibilities for correctness and completeness for the information published in this document and reserves the right to make changes at any time.